

TIME CONTROL

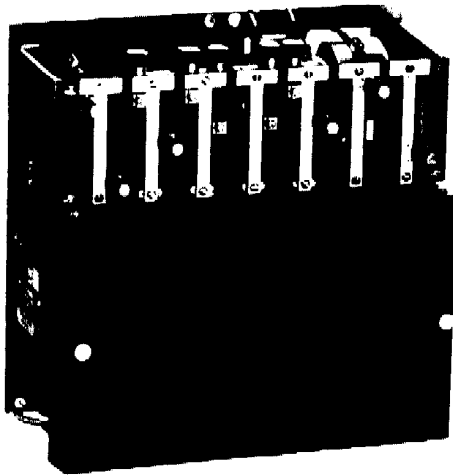

HM SERIES MULTIFLEX® Reset Timer



The MULTIFLEX® is a clutch operated, multiple circuit reset timer available in 10 standard time ranges, with up to 6 load circuits, and 4 standard timing adjustment combinations (contact forms).

Time ranges are from 5 seconds to 60 minutes, externally adjustable from zero to maximum of the chosen time range by two different means; a knurled thumbscrew for coarse adjustment, or a 10 to 1 ratio vernier for fine adjustment. Each ON or OFF adjuster has a companion scale 1.875" long, calibrated in the time range of the timer.

The timer is similar in action to a cam timer, except that each ON or OFF circuit is easily and conveniently adjustable during the timing period.

The unit is available in standard or reverse clutch operation. The reverse clutch unit will not reset on power failure. Maintained or momentary start operation is achieved by external wiring. The terminal board is spacious and the #10 screw terminals will accept #14 gauge wiring.

OPERATION

Energizing the clutch coil engages the clutch and lowers spring loaded contact trip bars to ride on a sliding plate. The motor drives the sliding plate down, winding a reset spring. The contacts open or close as the trip bars fall off the downward moving plate. Deenergizing the clutch coil disengages the clutch, raising the trip bars, and allows the spring loaded sliding plate to reset to its original position.

SPECIFICATIONS

Time Ranges

Sym	Time Scale	Linear Scale Divisions	Sym.	Time Scale	Linear Scale Divisions
N*	5 Sec	1-12 Sec	7	5 Min	5 Sec
1	15 Sec	1-4 Sec	8	10 Min	10 Sec
3	30 Sec	1-2 Sec	9	15 Min	15 Sec
4	60 Sec	1 Sec	B	30 Min	30 Sec
5	120 Sec	2 Sec	C	60 Min	1 Min

*Requires Heavy Duty Motor

Accuracy

Time intervals starting at "0" may vary 1% of full scale
Time intervals between indicators set 3/4 or more linear scale divisions from "0" will repeat consistently within 1.4 of 1% of full scale. This refers to repeated operations with the same setting.

Mounting

Vertical ONLY

Minimum Setting

The minimum setting from "0" is 3/4 of a linear scale division of 1% of full scale.

Reset Time

0.4 seconds from full scale setting

Number of Frame Sizes

2, 3, 4, 5, and 6 Circuits, Standard.

Each timer has one circuit for timer control in addition to those listed above.

Output Rating

10 Amps, Resistive, 120 VAC

5 Amps, Resistive, 240 VAC

3 Amps, Resistive, 440 VAC

Solenoids having inrush currents 3 times the above ratings can be controlled directly by the contacts

Voltage/Frequency

120 VAC (+10 -15%) 60 Hz

240 VAC (+10 -15%) 60 Hz

Burden

120 VAC 60 Hz

Inrush

42.5 VA

Maintained

46 / VA

Operating Temperature

+32°F to +140°F (0° to 60°C)

Laboratory Testing

C.S.A. Certification LR-26861 

Request Bulletin 130C for additional specifications, operating and maintenance instructions. Timer parts list, Bulletin 130E, is also available.

Eagle Signal Controls

A Division of Mark IV Industries, Inc.
8004 Cameron Road, Austin, Texas 78753 U.S.A.

TIME CONTROL



MULTIFLEX[®] BASIC TYPES

Each contact of the MULTIFLEX[®] Timer is available in the following forms.

Slide Adjustment — Loosening a thumbscrew permits sliding an indicator along the linear scale. This type is satisfactory where settings need not be more accurate than 1/2 linear scale division (approximately 1% of full scale).

Verniers — Used where accurate or frequent settings are made. The slide indicator is mounted on a screw which extends the full length of the linear scale. One turn of the vernier knob moves the slide 1 linear division. The vernier knob is calibrated in 10 sub-divisions. To make accurate settings, always turn vernier knob for a slightly longer setting and then return knob back to required setting. This will provide a setting accurate to within 2 vernier divisions or 1/3 of 1% of full scale.

NORMALLY OPEN Contacts When Timer is Deenergized or OFF

When timer is started, the contact closes at setting of "ON" indicator and opens at setting of "OFF" indicator.

NORMALLY CLOSED Contacts When Timer is Deenergized or OFF

Contact opens during timing and remains open. Closes when timer is deenergized and resets.

SYMBOL 2

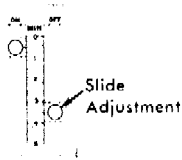

Thumbscrew ON
Thumbscrew OFF

SYMBOL 4

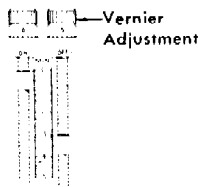

Micrometer ON
Micrometer OFF

SYMBOL 8



Thumbscrew OFF
Thumbscrew ON

Contact opens during timing at "OFF" setting; then recloses at "ON" setting.

SYMBOL 9



Micrometer OFF
Micrometer ON

MOUNTING DIMENSIONS

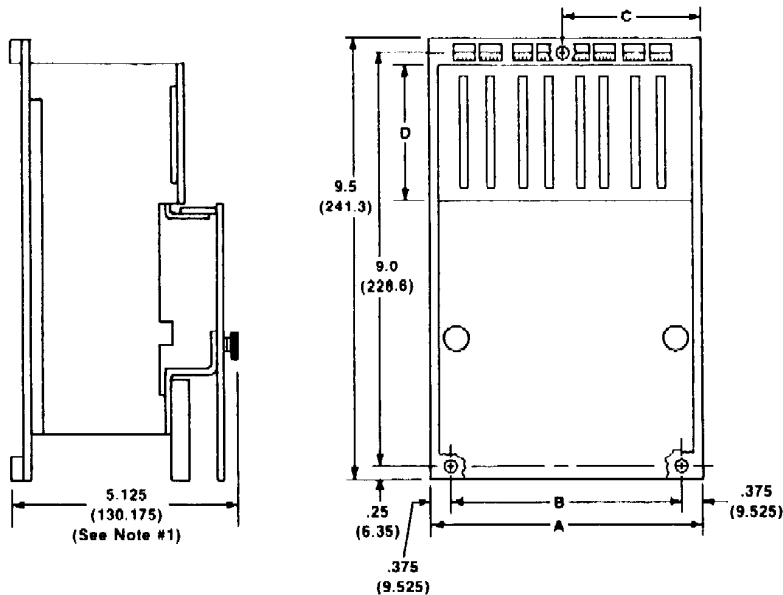

NOTES:

- 5.125 (130.175) depth is increased to 5.75 (146.1) when spring clip terminal board feature is used.
- Dimensions in parenthesis are millimeters.
- Heavy duty motor increases "A" dimension 2.5 (63.5).

DIMENSION	HM3	HM4	HM5	HM6	HM7
A	4.75 (120.65)	6.0 (152.4)	7.25 (184.15)	8.5 (215.9)	9.75 (247.65)
B	4.0 (101.6)	5.25 (133.35)	6.5 (165.1)	7.75 (196.85)	9.0 (228.6)
C	2.375 (60.32)	2.375 (60.32)	4.75 (120.65)	4.75 (120.65)	4.875 (123.82)
D	3.25 (82.55)	3.25 (82.55)	3.25 (82.55)	3.25 (82.55)	3.25 (82.55)

TIME CONTROL



HM

WIRING DIAGRAMS

Bold Lines are Internal Wiring

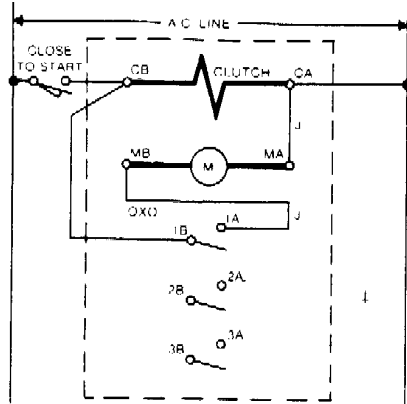

Figure 1

Close switch to start timing. Open to reset.

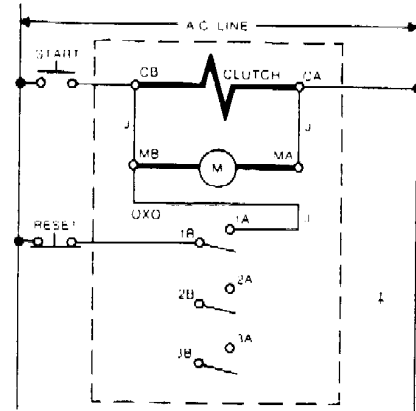

Figure 2

Momentary Start, Automatic Reset — With manual reset switch

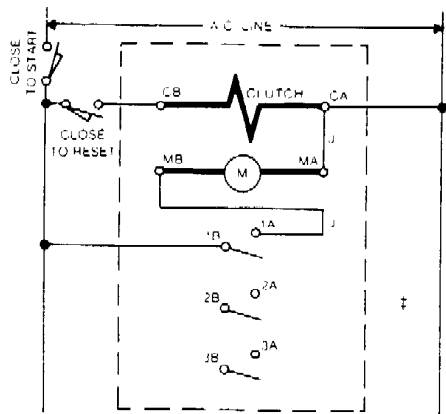

Figure 3

Reverse Clutch ("03" Feature) — Application of power to clutch resets timer. Non reset on power failure

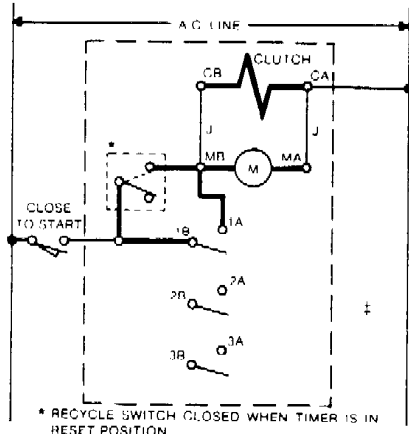

Figure 4

Repeat Cycle Attachment — Close switch. Timer clutch coil energized, contact 1A-1B closes. As timing plate moves away from "0", recycle switch opens. Clutch coil is held energized by contact 1A-1B. Set "OFF" indicator of 1A-1B circuit at point where timer is to reset. When timing plate has returned to "0", recycle switch A recloses, clutch coil is reenergized and new cycle starts. There may be as much as 1 scale division (1/60 of full scale) variation in timing of all circuits set to close at "0". This variation can be eliminated from the contact closed intervals if the "ON" indicators for load circuits are set at one scale division instead of "0".

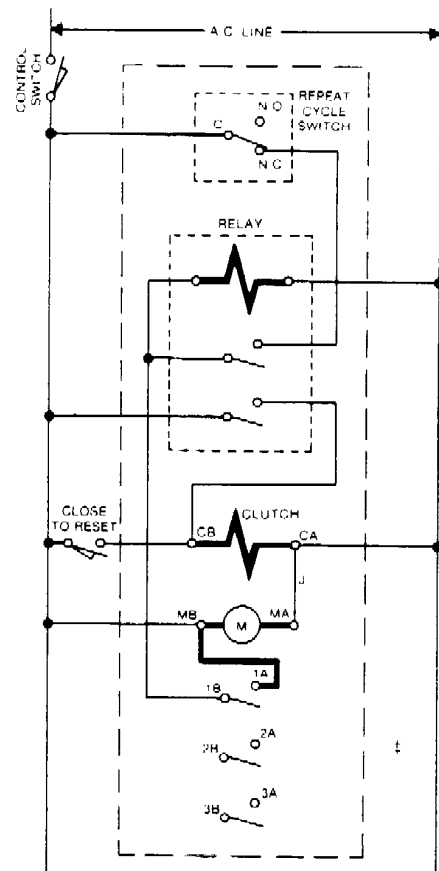

Figure 5

Repeat Cycle Operation. Timer does not reset on power failure. — Close control switch. Timer starts timing from point in cycle where timing was interrupted. "T" circuit (1A-1B) closes at END of time interval to "pick-up" relay. Relay locks in through one contact and energizes clutch coil of timer thru other contact. "Lock" in contact of relay in series with N.C. recycle switch contact which opens when timer traveling cam plate restores to reset position. Cycle repeats. NOTE: Relay to be furnished by customer

J = Load Switches. Opening and closing times determined by adjustment.
J = Jumper

TIME CONTROL



ORDERING INFORMATION

Consult Eagle for availability of other time ranges, voltages, and frequencies.

HM 3 1 A6 4 4 J 0 0 0 Z
See Below

BASIC UNIT

SYMBOL	NUMBER OF LOAD CIRCUITS*	TOTAL NO. OF CIRCUITS
3	2	3
4	3	4
5	4	5
6	5	6
7	6	7

* Each timer has a timer motor control circuit in addition to the number of load control circuits shown above

VOLTAGE & FREQUENCY

SYMBOL	VOLTAGE & HZ
A6	120VAC 60Hz
B6	240VAC 60Hz

STANDARD TIME RANGES

SYMBOL	TOTAL TIME SCALE	LINEAR SCALE DIVISIONS
1	15 Sec	1.4 Sec
3	30 Sec	1.2 Sec
4	60 Sec	1 Sec
5	120 Sec	2 Sec
7	5 Min	5 Sec
8	10 Min	10 Sec
9	15 Min	15 Sec
B	30 Min	30 Sec
C	60 Min	60 Sec

CIRCUIT CONTACT FORMS AND FEATURES

1. If feature is not required, select contact form number for the indicated circuit. Place that number in the indicated part number position. See Bulletin 140 for more information on contact form numbers.
2. If feature is required, place the corresponding letter for the desired circuit, contact form in the indicated part number position.
3. If timer does not have the indicated number of circuits, and the feature is not required, place the number zero (0) in the unused part number positions 10-13.
4. If timer does not have the indicated number of circuits but the feature is required, place the letter Z in the indicated part number position.

PART NUMBER POSITION	CIRCUIT NUMBER	DESCRIPTION	2	4	8	9	
7	1*	CONTACT FORM NUMBER	2	4	8	9	
		REPEAT CYCLE FEATURE	G	J	N	P	
8	2	CONTACT FORM NUMBER	2	4	8	9	
		MOTOR CUT-OUT SWITCH FEATURE	G	J	N	P	
9	3	CONTACT FORM NUMBER	2	4	8	9	
		REVERSE CLUTCH FEATURE	G	J	N	P	
10	4	CONTACT FORM NUMBER	2	4	8	9	0
11	5	CONTACT FORM NUMBER	2	4	8	9	0
12	6	CONTACT FORM NUMBER	2	4	8	9	0
		REMOVABLE TERMINAL BOARD FEATURE	G	J	N	P	7
13	7	CONTACT FORM NUMBER	2	4	8	9	0
		HEAVY DUTY MOTOR FEATURE	G	J	N	P	Z

4 4 J 0 0 0 Z

* Timer Motor Control Circuit Controls overall cycle length. Other circuits are load control circuits